

FORM N: DETAILED SPECIFICATIONS 24002

SUPPLY AND INSTALLATION OF ALUMIMUM SERVICE BODY and CRANE

INSTRUCTIONS FOR COMPLETION OF SPECIFICATIONS

- 1.1 All items in these specifications should be answered indicating compliance or non-compliance.
- 1.2 **Bidder shall state “yes” for compliance or state “deviation”**, or give a reply where requested to do so. Deviations and/or equivalents shall be clearly stated and fully detailed. Deviations and/or equivalents will be considered subject to evaluation. In every instance where a brand name or design specifications is used, the City will also consider deviations and/or equivalents.
- 1.3 Lengthy explanations of deviations may be included in a separate document and must reference the appropriate Detailed Specification.
- 1.4 Each Proponent is required to fill in every blank. Failure to do so may be used as a basis for rejection of bid.
- 1.5 It will be the responsibility of the Proponent to inform the City of any errors or omissions in these Detailed Specifications, for under this Contract, the Contractor shall be held responsible to ensure that the manufacturer will be responsible for the design, performance, reliability and satisfactory operational function of the unit.

2.0 DESCRIPTION OF EQUIPMENT

- 2.1 These specifications describe the supply and installation of an **Alumimum Service Body and Crane** and other equipment and features as specified herein.
- 2.2 The **Alumimum Service Body and Crane** shall be a new **2024** model year or newer.
- 2.3 The **Alumimum Service Body and Crane** and all other items/components shall be the manufacturer's latest model. The equipment shall be furnished complete and ready for operation. Any parts or accessories not specifically mentioned, but which are required to complete and place the equipment and associated attachments in successful operation shall be furnished as though specifically mentioned in these specifications. The equipment and associated attachments, and all parts thereof, shall conform in strength and quality of material and workmanship, to the best standards and engineering practice of the industry.
- 2.4 The ratings specified herein merely state the minimum values acceptable to the City, not implying that those values are sufficient for the design of the particular equipment being bid.

3.0 OTHER SPECIFICATIONS AND STANDARDS

- 3.1 All applicable SAE standards form an integral part of these specifications and shall have precedence in any conflict concerning minimum acceptable standards.
- 3.2 **Where applicable**, the **Alumimum Service Body and Crane** shall comply with the applicable regulations:

Standard - Specification/Regulation

Internet URL

Transport Canada, National Safety Mark, NSM:	http://www.tc.gc.ca/eng/acts-regulations/acts-road.htm
Manitoba Safety and Health Regulation, Parts 12, 16, 22:	http://web2.gov.mb.ca/laws/regs/current/217.06.pdf
Canadian Motor Vehicle Safety Standards C.M.V.S.S.:	http://laws-lois.justice.gc.ca/eng/regulations/C.R.C.,_c._1038/section-sched3.html

Standard - Specification/Regulation

Internet URL

Manitoba Highway Traffic Act regulations and requirements including, but not limited to, a Manitoba Government Inspection with Safety Sticker:

<http://web2.gov.mb.ca/laws/regs/index.php?act=h60>

Canadian Standards Association CSA:

<http://www.csagroup.org>

Under Writers of Canada U/L:

<http://www.ulc.ca>

Society of Automotive Engineers SAE:

<http://www.sae.org>

City of Winnipeg Lighting Visibility Standard:

<http://winnipeg.ca/matmgt/pdfs/PublicWorksEquipLightingVisibility.pdf>

Manitoba Building Code:

https://web2.gov.mb.ca/laws/regs/current/_pdf-regs.php?reg=31/2011

3.3 Where applicable, the completed unit shall include a Manitoba Government Inspection with Safety Sticker.

3.4 Where applicable, the manufacturer/installer shall be a certified vehicle completer and must affix their National Safety Mark (NSM) certification sticker on each unit.

State NSM number: _____

4.0 FUEL

4.1 Where applicable, the equipment shall be fully fuelled upon delivery (no exceptions).

5.0 REFERENCES

5.1 If available, please provide five (5) references where this equipment is used in a working environment where climatic conditions are similar to the City of Winnipeg.

6.0 MAKE & MODEL

6.1 State year, make and model being bid:

Model Year: _____

Make: _____

Model: _____

7.0 PERFORMANCE RELIABILITY

7.1 The responsibility for the design of the **Alumimum Service Body and Crane** its performance and reliability shall rest upon the Contractor.

- 7.2 The term “repeated failures” as used herein is defined to mean that the same component, subassembly, or assembly develops repeated defects, breakdowns and/or malfunctions rendering the vehicle inoperative, or requiring repeated shop correction, service and/or replacement during the warranty period applicable for said component, subassembly, of assembly. Minor items or ordinary service adjustments are not included, or considered under the scope of “repeated failures”, as well as other factors, such as operational damage due to accidents, misuse or lack of proper maintenance, service and lubrication attention by not following the manufacturer’s preventative maintenance schedule.
- 7.3 Where the **Alumimum Service Body and Crane** develops “repeated failures” in service, the Contractor shall make any necessary engineering changes, repairs, alterations or modifications in order to guarantee reliability of performance.
- 7.4 The equipment shall be capable of consistent top performance in City of Winnipeg Environment. **Note: The City of Winnipeg has four seasons with ambient temperatures ranging from approximately 90°F (32°C) to -40°F (-40°C).**

8.0 **SERVICE FACILITY**

- 8.1 For the purpose of warranty repairs, the Bidder shall have an authorized service facility. The facility, or a portion thereof, shall be dedicated to the service and maintenance of the type equipment being offered. Bidders shall provide a description of the service facility including, but not limited to, number of qualified service staff, years of service experience, and general service capabilities within three (3) Business Days upon request of the Contract Administrator.

9.0 **QUALIFICATIONS OF MANUFACTURER & CONTRACTOR**

- 9.1 The manufacturer of the **Alumimum Service Body and Crane** shall have five (5) years continuous experience manufacturing **Alumimum Service Body and Crane**.
- 9.2 The manufacturer shall have in effect a documented quality control program ensuring that the quality of materials and workmanship, including welding, conforms to the best standards and engineering practice of the industry.
- 9.3 The Contractor shall have five (5) years continuous experience servicing, repairing and maintaining **Alumimum Service Body and Crane** of the type being offered.

Representative Picture Typical Completed New Alumimum Service Body and Crane on Truck Chassis Pictured below – Passenger’s Side View - (R1).



10.0 **SPECIFICATIONS**

Scope

10.1 Supply and Delivery of an **Alumimum Service Body and Crane** complete with steel deck which will be mounted on a City owned cab and chassis. _____

Supply and Delivery of a 10,000-ft-lb telescopic **Crane** to be installed at the rear, passenger side top compartment (R1) of the service body.

The **Alumimum Service Body** shall be capable of supporting the **Crane** described in these specifications.

The **Alumimum Service Body and Crane** shall be capable of consistent top performance for loading and hauling varying payloads year-round in conditions normal to the City of Winnipeg.

Body and accessories to be mounted by a CMVSS certified installer in accordance with CMVSS regulations as well as the chassis and body manufacturers recommendations.

Note: The City of Winnipeg has four seasons with ambient temperatures ranging from approximately 90°F (32°C) to -40°F (-40°C)

Make and Model – Service Body

- 10.2 Make **State:** make: _____
- 10.3 Model **State:** model: _____
- 10.4 Model Year **State:** model year: _____

Body Weights

- 10.5 Body Weight – Service Body **State:** estimated weight of service body

- 10.6 Body Weight – Crane **State:** estimated weight of crane

10.7 **Weight Scale Ticket**

Weigh Scale Ticket: _____

- The Contractor shall provide a certified weigh scale ticket upon delivery of the completed unit
- The scale ticket shall include front and rear axle weights including two (2) operators, all attachments and full of fuel.

Manitoba Inspection (MGI)

- 10.8
- The Contactor shall provide completed/valid MGI upon delivery of the completed unit. _____
 - MGI documentation shall be valid upon release in accordance with an approximate 12-month period application or effectiveness.

Installation

10.9 **Alumimum Service Body and Crane will be installed** on the following City owned cab & chassis vehicle:

City Winnipeg Department/Customer	Vehicle Type/Style	Quantity	Description	New Vehicle Unit Number (WFMA)
WW-WSTWTR-INTERCEPTION	2023 Ford F-550	1	19,500 lbs. GVWR Gas, 4WD Crew Cab; 60 (Cab to Axle Length CA), 7.3 L, V8 Gasoline engine TorqShift® 10-Spd. Automatic Horizontal discharge exhaust, Ford Oxford White Code Z1	2203505

10.10 **Availability** The cab chassis will be available during the first quarter of 2024

- 10.11 Pick-Up
- The Contractor shall be responsible for picking-up the chassis cab vehicles from the City upon commencement of the Contract
 - The vehicles will be available for pick-up at the Winnipeg Fleet Management Agency, 185 Tecumseh St., Winnipeg, Manitoba
 - Pick-up times will be between 8:00 am and 2:00 pm on any Monday to Friday Business Day
 - The Contractor shall be responsible for any related fuel and Insurance costs to and from their facility

Note: The vehicles will be fully fuelled at the time of pick-up by the Contractor

10.12 **Drawings**

Drawings – Contractor shall supply

- The Contractor shall supply multi-view CAD drawings to the Contract Administrator upon Award of Contract
- Drawings will be reviewed and approved as part of the Pre-Production planning stages
- Contractor to provide a weight analysis after pre-production meetings
- Drawings are to include all dimensions, materials, and specifications as required
- Drawings are to be revised as requested by the City
- Multiple drawing iterations may be required
- Construction of the service body shall not commence until approval is granted

Note: Drawings can be supply as hard copies, PDF's or electronically

Service Body

- | | | | |
|-------|-----------------------|---|----------------|
| 10.13 | Alumimum | <ul style="list-style-type: none">• High strength alumimum substructure service body primed and painted with two (2) coats of plastic urethane paint• Colour impregnated to match chassis cab colour (Ford Oxford White Z1) | _____ |
| 10.14 | Compartment Interiors | Left in natural unpainted finish | |
| 10.15 | Material | <ul style="list-style-type: none">• Corrosion-resistant 10 gauge 5052-H32 marine grade alumimum• The <u>mill certification</u> for the material grade 10 gauge 5052-H32 alumimum marine grade shall be provided or available to the inspector upon request or Contract Administrator.• Double sided construction• Internally reinforced compartment doors <p>State: material thickness: _____</p> | _____
_____ |
| 10.16 | Compartment Layout | Each side of vehicle to have: <ul style="list-style-type: none">• one (1) front vertical compartment• one (1) horizontal compartment over the wheel well• one (1) rear vertical compartment | _____ |

General Dimensions

For the purpose of these specifications:

- L – Length along or parallel to chassis longitudinal axis.
- H – Height, vertical.
- D – Depth on horizontal plane across vehicle

Note: Unless otherwise specified, all dimensions are in inches and are the nominal sizes.

- Left and right is always based on perspective when sitting in the vehicle, so:
- Driver side is the left - L1
- Passenger side is on the right – R1.

- The designations for the driver's side may be referred to as L1 within the documentation.

- The designations for the passenger's side may be referred to as R1 within this documentation.

10.17	Body Height	<p><u>Driver's Side – L1</u></p> <p><u>Approximately 50 in. L1 side (front compartment only).</u> Remaining compartments range from approximately 25" - 40" height.</p> <p><u>Passenger's Side – R1</u></p> <p><u>Approximately 50 in. R1 side (front compartment only).</u> Remaining compartments range from approximately 25" – 40" to accommodate for crane mounting on rear compartment of service body.</p>
10.18	Body Length	Approximately 109" in. (work platform included)
10.19	Body Width	Approximately 94" – 96" in.
10.20	Deck Width	Approximately 50" – 55" inches between aluminum side packs
10.21	Under Deck Floor	1/8" Steel plate

Representative Picture of Aluminum Service Body

This image shown for illustration purposes only and may not be an exact representation of the final product but should be a similar configuration and style functionality.

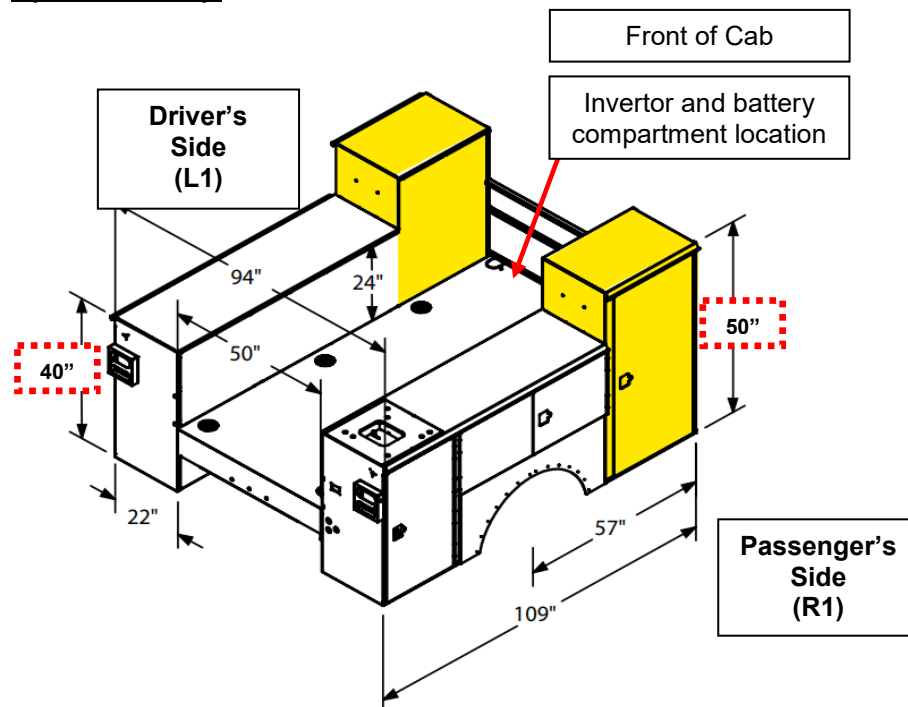

Service Body Compartment Layout, Driver's Side - (L1)

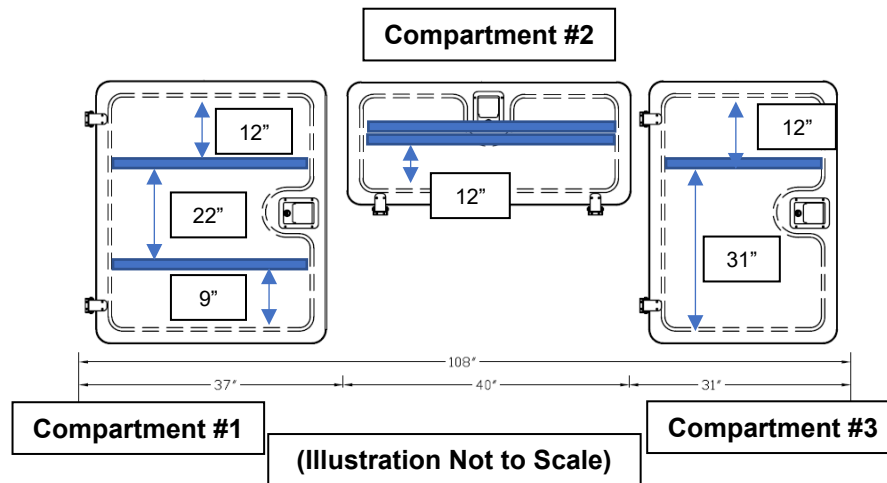

The present configuration of the service body compartment. (Driver's Side – L1)

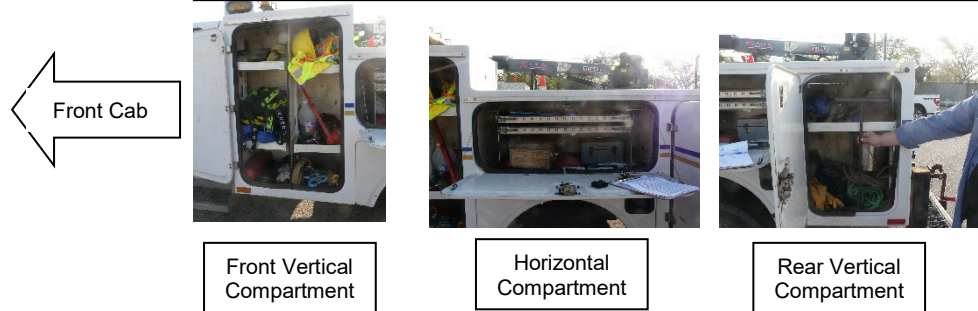

COMPARTMENT SIZES – Approximate Dimensions

1	37" W x 50" H	19.5" - 22" D
2	40" W x 25" H	19.5"- 22" D
3	31" W x 40" H	19.5" – 22" D
Length 109" inches	Height range approximately 24" – 60" inches	Width 95.25" – 96" inches
Approximate Estimated Weight 2,125 lbs		

Compartment #1 – Driver's Side

10.22

Front Vertical
Compartment #1
(Behind truck cab)

- Compartment # 1
- Approximately 37" Length x 50" Height x _____ Depth
- Fixed trays installed
- Qty one (1) 1 Top tray located 12" from top compartment with tray lip 2"
- Qty one (1) 1 Bottom tray located 22" from top tray. Tray lip 2"
- 250 lb. minimum load capacity

State:

Compartment Size: _____

Tray Size(s): _____

Compartment #2 – Driver’s Side

10.23 Horizontal
Compartment #2
(over wheel well)

- Compartment # 2
- Approximately 40” Length x 25” height H x 22” Depth _____
- Qty (2) pull out top trays – bottom tray located 12” from bottom of compartment with tray lip 1”.
- 250 lb. minimum load capacity

State:

Compartment Size: _____

Tray Size(s): _____

10.24 Rubber Bumpers

- Installed on the body below the horizontal compartments to prevent contact between the compartment door and the body _____
- Two (2) bumpers per door

Compartment #3 – Driver’s Side

10.25 Rear Vertical
Compartment #3
(Hooks)

- Compartment # 3
- Approximately 31” Length x 40” Height x 22” Depth _____
- Qty one (1) Fixed top shelf located 12” from top compartment with tray lip 2”
- 31” approximate opening from top shelf. Two (2) hooks on each sidewall
One (1) shovel hook centered on back wall
- Rubber material mounted on walls behind hooks to protect service body wall and prevent damage to the service body structure.
- 250 lb. minimum load capacity

State:

Compartment Size: _____

Shelf Size(s): _____

Number of Hooks: _____



Service Body Compartment Layout, Passenger's Side (R1)

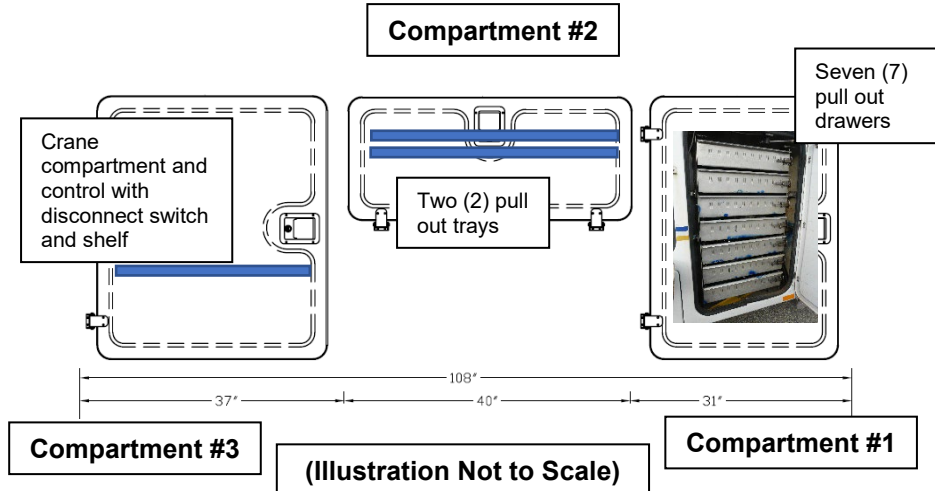

The present configuration of the service body compartment. (Passenger's Side – R1)

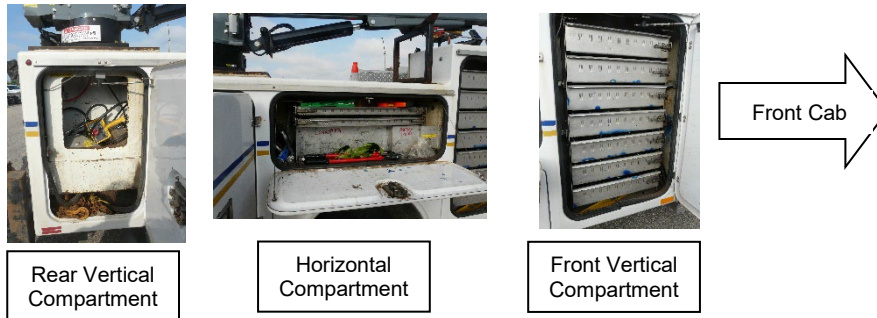

COMPARTMENT SIZES – Approximate Dimensions

1	37" W x 50" H	19.5" - 22" D
2	40" W x 25" H	19.5" - 22" D
3	31" W x 40" H (Crane Location)	19.5" – 22" D
Length 108 inches	Height range approximately 24" – 60" inches	Width 95.25" – 96" inches
Approximate Estimated Weight 2,125 lbs		

Compartment #1 – Passenger's Side

10.26

Front Vertical
Compartment # 1
(Behind truck cab)

- Compartment # 1
- Approximately 37" Length x 50" Height x 22" Depth
- Qty seven (7) cabinet draw pullout all drawers same size
- 250 lb. minimum load capacity
- 250 lbs heavy duty draw slides

State:

Compartment Size: _____

Cabinet/draw Sizes: _____

Compartment #2 – Passenger’s Side

10.27 Horizontal
Compartment #5
(over wheel well)

- Compartment # 2
- Approximately 40” Length x 25” Height x 22” Depth _____
- Qty (2) pull out top trays – bottom tray located 12” from bottom of compartment with tray lip 1”.
- 250 lb. minimum load capacity
- 250 lbs. heavy duty drawer slides

State:

Compartment Size: _____

Tray Size(s): _____

10.28 Rubber Bumpers

- Installed on the body below the horizontal compartments to prevent contact between the compartment door and the body _____
- Two (2) bumpers per door

Compartment #3 – Passenger’s Side

10.29 Rear Vertical
Compartment #3
(Crane compartment)

- Compartment # 3
- Approximately 31” Length x 40” Height x 22” Depth _____
- Crane storage area
- Compartment shall be reinforced as required to accommodate a 10,000-ft-lb telescopic crane as specified in these requirements
- Independent of all other compartments

State:

Compartment Size: _____

Reinforcement of Cabinet: _____

Rear Vertical
Compartment #3 – Illustration
Crane Reinforcement

Representative Picture of
Alumimum Service Body with
crane reinforce compartment –
This image shown for illustration
purposes only and may not be
an exact representation of the
final product.

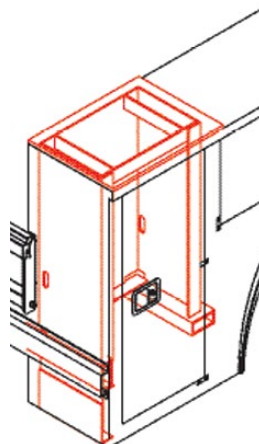

Tailgate and Under Deck Compartment

Tailgate

10.30 Tailgate

- Automotive style tailgate
- Tailgate, 12-Gauge – automotive style tailgate, corrosion-resistant 5052-H32 marine grade aluminum construction for rust preventative, approximately 14” – 16” in. height, fold-down style with check chains.
- All components corrosion protected
- Approximately 10” inches height
- Load rating of approximately 350 lbs.
- Fold-down style with check chains or slam style spring latch with hidden stop opening to 90 degrees

State: _____

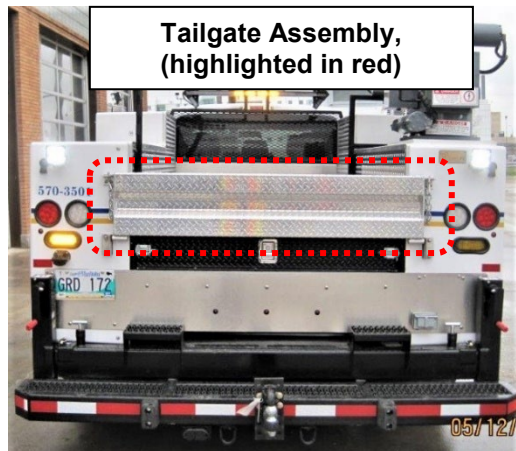

Under Deck Compartment

10.31 Tailgate Under Deck
Compartment

- 3/16 in. galvanized steel construction corrosion-resistant
- Fold-down type with heavy duty hinges
- Chrome or stainless-steel paddle style door handle and latch

Lubrication

- Grease fitting required on each hinge
- Or
- Hinge assembly and hinge pin is aluminum and has enough clearance that it will not seize up over time
 - The end of the hinge is open and can be sprayed with lubricant if desired



10.32 Pull-out Tray

- Rectangular pull-out tray
- Approximately 106" – 122" inches long x 7" inches height x 46" inches width
- Locking mechanism quick release for access for pull-out tray draw.

State:

Compartment Size: _____

10.33 Drain Holes

- 3/4" inch drain holes required at front of under deck compartment

Illustration and picture showing under deck pull out compartment located at the rear of the tailgate.

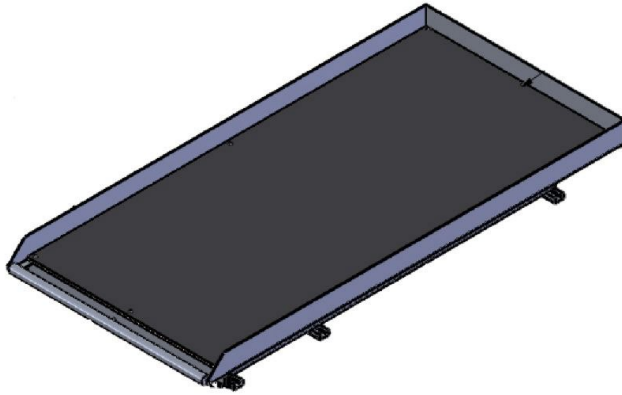

These images shown for illustration purposes only and may not be an exact representation of the final product but should be a similar configuration and style/functionality.

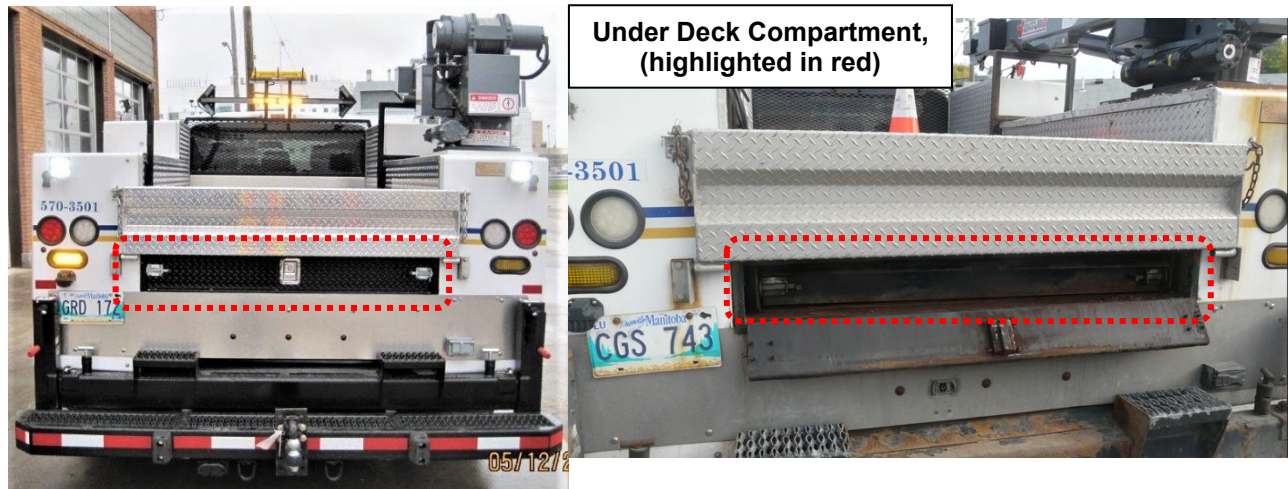

Standards – Aluminum Service Body (Where Applicable)

- | | | | |
|-------|----------------------------|--|--|
| 10.34 | Service Body/Truck Chassis | Service body must be attached to the truck chassis and properly supported. i.e. bolted and automotive grade U-bolts used to secure service body to truck chassis main frame members. | |
|-------|----------------------------|--|--|

Note: in some cases, the following must be conducted in accordance with service body manufacturers specifications for installation.

Body and accessories to be mounted by a CMVSS certified installer in accordance with CMVSS regulations as well as the chassis and body manufacturers recommendations.

EXAMPLE: Ford & Ram Specific Requirements – The under structure of the service body must be attached to the truck frame using a minimum of four points. The front two mounts closest to the cab of the truck must be spring mounted.

Exception for Aerial/Crane Device equipped Service Bodies: If an aerial/crane device is involved, the body is to be spring mounted at the opposite end of the device at the two-service body under structure to truck frame attachment points.

After the installation of the body to the chassis verify:

- Doors shut and seal correctly, if not, adjust striker assembly
- Master Lock Rod System, if equipped, functions as advertised, if not, adjust components

After the adjustments are made, perform a water intrusion test.

- | | | | |
|-------|---------------------------------|---|--|
| 10.35 | Compartment Floor Reinforcement | Compartments #3 shall be lined with a 3/16" in. steel plate covered with rubber matting | |
|-------|---------------------------------|---|--|

10.36	Compartment Floor Lining	Compartment #1 and #2 shall be lined with Dri-Dek material or equivalent material having same material specifications	_____
10.37	Isolators	<ul style="list-style-type: none">• All interfaces between aluminium and steel are to be separated by an approximately $\frac{1}{16}$ in. thick rubber or neoprene sheet• Shall be bolted through with stainless steel bolts and non-conductive bushings	_____
10.38	Drain Holes	All body compartments to include a $\frac{1}{2}$ in. drain hole complete with plug	_____
10.39	Doors Design and Weather Stripping	Automotive door design with neoprene seals or equivalent seals having same specifications to minimize moisture and dust intrusion. Automotive grade weather stripping.	_____



10.40	Doors	All vertical compartments doors to vertically hinged	_____
10.41	Door Latches	<ul style="list-style-type: none">• Flush mounted with locks for all compartment doors• All locks shall be keyed alike	_____
10.42	Compartment Door Handles	Tri-Mark door handles, Chrome plated or stainless-steel paddle style handles or equivalent model having same specifications	_____
10.43	Door Hinges and Latches	Chromed or stainless steel with adjustable striker plates	_____
10.44	Compartment Door Openings	Sealed using automotive type bulb gasket door seal	_____
10.45	Door Hold-Open Devices	<ul style="list-style-type: none">• Over-centre door holders on front and rear compartments• Detachable cables on horizontal compartments	_____

10.46 Cabinet Locks

- Service Body cabinets to be keyed to the same key for all cabinets.
- Master Locking system to be installed on both side of the service body for all compartments



Representative Picture of Master Lock System for Aluminum Service Body with crane. – This image shown for illustration purposes only and may not be an exact representation of the final product.

10.47 Service Body Cabinet Light (LED) System

- Aluminum service body cabinets, all to be illuminated with integrated high performance and long-life LED lighting.
- Actuated when the doors are opened



Grab Handles

10.48 Grab Handles

- Located for ergonomic access to service body deck
- Diameter 1-1/4" inches (32mm) – 1-1/2" inches (38mm)
- Spacing behind grab bars is approximately 3" inches (76mm)
- Slip resistant
- Bolt on construction and affixed securely and positioned in a manner that does not impede or interfere with the tailgate assembly or obstruct any lighting
- Primed and painted high visibility yellow paint

Final design and installation to be finalized at pre-production meeting



Running Boards

- | | | | |
|-------|--------------|---|-------|
| 10.49 | Construction | <p>Custom made:</p> <ul style="list-style-type: none"> • Extending entire length of underside of front and rear doors, each side. • AGS 6061 aluminum grip strut, 9-1/2" inches x 2.0" inches x 0.08" inches • Inside kick plate shall consist of 1/8" inches aluminum checker plate • Support brackets shall consist of 1-1/2" inches x 1-1/2" inches x 1/8" inches RC aluminum square tubing with 1/4" inches aluminum support plates | _____ |
| 10.50 | Mounting | <ul style="list-style-type: none"> • Cab steps to be mounted using the existing holes in the frame and body where applicable • Use 3/8-16 nut inserts to secure the mounting brackets to the body | _____ |



- | | | | |
|-------|-----------------|--|-------|
| 10.51 | Wheel Well Area | <ul style="list-style-type: none"> • Shall incorporate a fibreglass or rubber fender flare • Wheel Well panels are removable | _____ |
|-------|-----------------|--|-------|

10.52	Drip Edge	<ul style="list-style-type: none">• Installed along the full length of the body above the door openings• Designed to prevent water from entering into the storage compartments	_____
		State: method _____	
10.53	Deck Width	Approximately 52 in. between side packs	
10.54	Deck Sides	<ul style="list-style-type: none">• $\frac{3}{16}$ in. aluminum checker plate; minimum grade 5052-H32 marine grade aluminum• Extended full height up sides of the side packs	_____ _____
10.55	Tie-Down Eyes	<ul style="list-style-type: none">• Eight (8) total• Corrosion protected• One (1) required near each corner of floor/deck flush mounted• Two (2) equally spaced on inside of side packs, mid-height, each side• Floor mounted tie-down eyes rated for lifting service body with an overhead crane• Three (3) total• Corrosion protected• One (1) mounted near each corner of the inside wall of service body, flush mounted is possible.• One (1) mounted in the middle of inside wall of service body, flush mounted if possible.	_____
		State: method of corrosion protection: _____	
10.56	Front Headboard	<ul style="list-style-type: none">• $\frac{3}{16}$" inch aluminum checker plate• Approximately 52 in.• Top of headboard shall not protrude higher than the lower portion of the rear truck window	_____
10.57	Kick Plate, Rear of Body	<ul style="list-style-type: none">• $\frac{3}{16}$" inch. Aluminum checker plate• Full width below deck floor level	_____
10.58	Kick Plate, Front	<ul style="list-style-type: none">• $\frac{3}{16}$" inch. aluminum checker plate (corrosion-resistant 5052-H32 marine grade aluminum) to protect lower front area of body protruding past chassis cab• Each side• Approximately 8 in. kick plate height	_____
10.59	Sealant	Deck sides and kick plates caulked along edges using automotive grade elastomeric sealant	_____

Rear Bumper and Receiver – Truck Chassis/Service Body

- 10.60 Rear Bumper and Receiver
- Supply/build and install a custom-made rear bumper complete with receiver and hydraulic outriggers for the crane side of the truck service body



Crane – Mounted to Service Body

Crane - Representative Picture of Service Body Crane – This image shown for illustration purposes only and may not be an exact representation of the final product but should be a similar configuration and style.



- 10.61 Make
- Auto Crane, Venco Venturo Crane or Equivalent model having same industry specifications 10,000 ft-lbs (1.38 ton-m) moment rating and a maximum lifting capacity of 3,200 lbs.

State: _____

- 10.62 Model
- State:** _____

- 10.63 Model Year
- State:** model year: _____

- 10.64 Type
- Electric-Hydraulic
 - Rear corner mounted on passenger side (R1) top rear cabinet
 - Telescopic

- 10.65 Rating
- Approximately 10,000 ft-lb
- State:** _____

10.66	Lifting Capacities	Approximately 3,200 lbs. @ 2 ft. State: _____	_____
		Approximately 1200 lbs. @ 8 ft. State: _____	
		Approximately 1000 lbs. @ 10 ft. State: _____	
		Approximately 660 lbs. @ 15 ft. State: _____	
10.67	Mounting Location	Rear Curbside corner of service body on top of side packs Note: Service body to be reinforced in the rear compartment # 4 to allow for installation/operation of the crane.	_____
10.68	Reach	<ul style="list-style-type: none">• 15 ft. telescopically extendable boom length• <u>Hydraulic power boom extending to 15 ft.</u> State: boom extension details: _____	_____
10.69	Rotation	360 degrees continuous power rotation	_____
10.70	Crane Weight	State: estimated weight of crane _____	_____
10.71	Stowed Boom Length (Typical Stowed Boom Length 7'-5")	State: _____	_____
10.72	Extended Boom Length (Typical Extended Boom Length 1' 8.63")	State: _____	_____
10.73	Width (Typical Width 1' 8.63")	State: _____	_____
10.74	Height, In-Stowed Position Typical Height 2'	State: _____	_____
10.75	Base Plate Typical plate dimensions 1' 1.5" x 1' 4.75"	Must meet crane capacity requirements State: size and thickness _____	_____
10.76	Automatic Overload Protection System	Required: State: _____	_____

10.77 Remote Control Pendant

- Proportional control
- Tethered
- Removable
- Approximately 18 ft. of cable
- IP66 rated and CE certified
- Sealed and water protected for maximum durability.



Crane Tethered Controller -

Representative Picture of Crane Tethered Controller – This image shown for illustration purposes only and may not be an exact representation of the final product but should be a similar configuration and style.

10.78 Circuit Breaker

Required:
Minimum rated circuit breaker 150 Amp

10.79 Master Disconnect Switch

Required:
Lockout tag disconnect switch located in compartment #3.

Picture shown for illustration only of disconnect switch in compartment #3.

The final design may not be an exact representation of the final product but should be a similar configuration and style/functionality.



10.80 Outriggers

Required:

- Steel construction including all components for rear installation
- Outriggers shall include a heavy-duty cross tube rated for crane capacity
- **Hydraulic extendable** in/out outriggers for the crane on both sides on the rear of the service body for easy extension and retraction. Additionally, the legs of the outriggers can be adjusted hydraulically up/down.
- The outriggers shall be incorporated into a custom-made rear bumper.

Representative Picture of Hydraulic Crane Outrigger – This image shown for illustration purposes only and may not be an exact representation of the final product but should be a similar configuration and style/functionality.



10.81 Crane Cover

- Supply one (1) all weather crane cover for base crane assembly

10.82 Operator's Manual

Required:

10.83 Location – Crane

Rear vertical top compartment #3 –
Passenger Side (R1)

Location crane
mounted on
service body



Crane location on service body;
Representative Picture given for reference.
This image shown for illustration purposes
only and may not be an exact
representation of the final product.

Back-Up Alarm

10.84 Back-Up Alarm

- SWS model 99202 or equivalent model having same specifications and functionality



- Mounted between frame rails at rear of vehicle
- Protected from damage and road spray

Rear View Camera

10.85 Rear View Camera



- The cab and chassis will be supplied (unattached) with a rear-view camera
- Rear-view camera prep kit to include camera, screen (or displayed in rear view mirror) mounting hardware and OEM wiring harness
- To be installed by body supplier
- The installation of the rear-view camera is carried out by a professional installer in order to guarantee an unobstructed view during the process of reversing.

Conspicuity Tape

10.86 Conspicuity Tape

Truck-Lite 98127 or equal, affixed or equivalent model having same specifications

Grease Fittings

10.87 Grease Fittings

Required:
On tailgate release mechanisms, pivot points and drop-down side linkages

Inverter

10.88 Inverter

CSA approved

- 110 Volt, 3000 Watts minimum
- Make: Xantrex
- Model: XPower 3000 Inverter or equivalent rated unit model having same specifications or functionality
- Part Number: 813-3000-UL
- Mounted in the bed of the service body in cabinet/box, weather protected.

State:

Make: _____

Model: _____

10.89 Deep Cycle Battery

- Group 31, Deep Cycle AGM battery, approximately 900 CCA or equivalent Model
- Battery - Operating temperature range- 40°F / -40°C to 140°F / +60°C
- Battery Cold Start Performance S.A.E J537

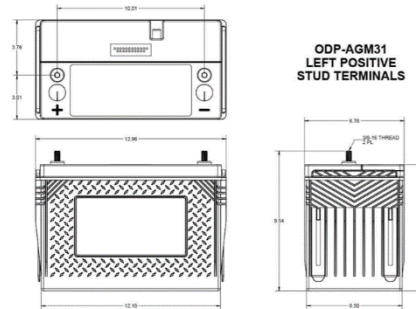

Mounted in the same location as inverter in a reinforced compartment in the bed of the service body

State:

Make: _____

Model: _____

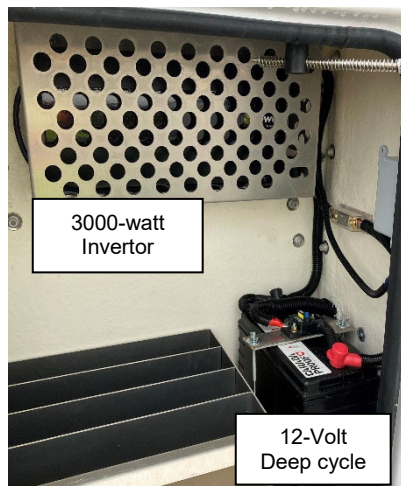

10.90 Installation

All exposed inverter terminals shall be:

- Coated with a dielectric grease
- Completely covered with adhesive-sealant-lined shrink tubing must be used to guarantee joint integrity, waterproofing and strain relief or rubber fittings
- The battery lid cover supplied to provide protection for the terminals, ensuring their shielding.

10.91 Location

Front of service body bed with inverter and battery mounted in self-contained aluminum box, weather protected.

10.92 Wiring

Location to be confirmed at pre-production meeting.

- Wired through ignition through dash mounted inverter mfg. remote switch
- Must be labeled – permanent and engraved
- Inverter to be complete with suitable solenoid and battery isolator
- The wiring should have the capability to carry approximately 14 volts of alternator charging voltage from the engine compartment (when engine running) to the deep cycle battery connected to the inverter.

10.93 Installation

No exposed inverter terminals

- Terminals coated with a dielectric grease
- Completely covered with adhesive-sealant-lined shrink tubing must be used to guarantee joint integrity, waterproofing and strain relief or rubber fittings

10.94 Receptacle

- One (1) required
- Duplex receptacle
- Mounted at front of service body, passenger side (Passenger Side – R1)
- Forward facing
- Mounted as high as practicable so as not to interfere with interior shelf positioning
- The Duplex receptacle shall be minimum 20 AMP, GFI, CSA approved
- Weatherproof type with hinged covers with automatic cover closure/spring closure mechanism built in to the housing cover.



Location to be confirmed at pre-production meeting.

Lighting

10.95 LED Lighting

10.96 Mini Light Bar - Amber

- All safety warning lights shall be Class 2 or equivalent specification
- Whelen, SWS or Grote Series Amber LED Mini Light Bar or equivalent
- Mounted to center top of traffic advisor signal

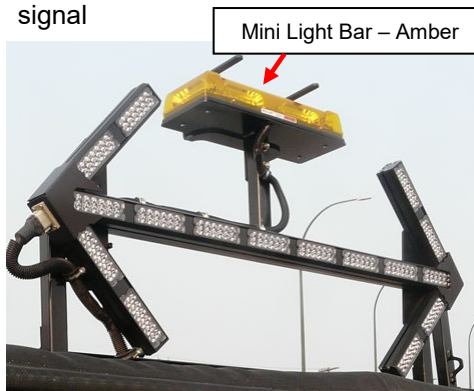

- Protected by branch guard – heavy duty construction
- Mini Light Bra shall be wired “Hot” (i.e. able to use without the key on) wired through a single OEM dash mounted switch or on the control panel enclosure. labelled “Light Bar” with a permanent type engraved style label
- Mounting of labels with 3M VHB Tape or equivalent
- Switch shall be capable of amber mode

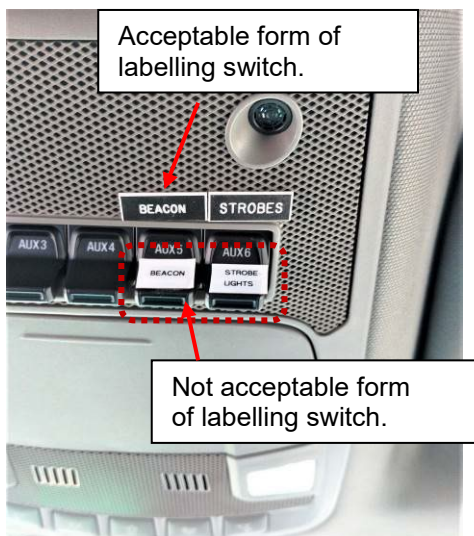

State:
Manufacturer: _____
Model: _____

10.97 Directional Arrow
(Traffic Advisor)

- SWS, Whelen, or Grote or equivalent functionality, Class 2
- Approximately 48 in. x 22 in.
- Cab shield mounted
- Rear facing
- Controller mounted in-cab, reference pictures below for mounting location.

State: _____

Manufacturer: _____

Model: _____



If a factory overhead switch cannot be Utilized for some lighting control, the recommended placement for the traffic adviser and switches is shown in the preferred mounting location.

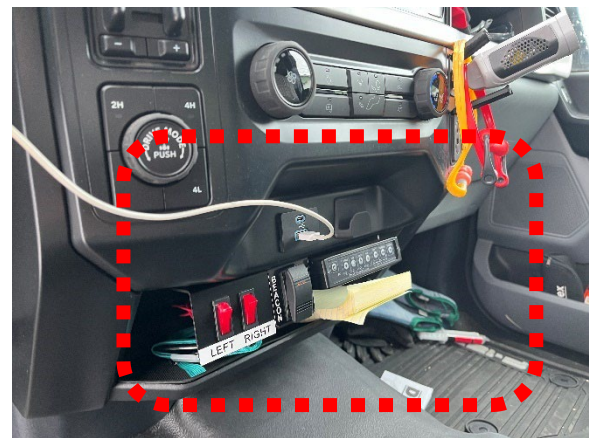

➤ Location to be confirmed at pre-production meeting.

Lighting – Where applicable/requirement in accordance with application.

10.98 Amber Strobe Lights
(Warning)
(360 safety visibility requirement)

- Four (4) total
- Whelen, SWS or Grote Series lighting Class 2 or equivalent
- Mounting garments flush with service body
- Two (2) located outside of 3-Light cluster, rear facing in rear kick plate
- Two (2) located in service body facing near front
- Amber Strobes shall be wired “Hot” (i.e. able to use without the key on) wired through a single OEM dash mounted switch or on the control panel enclosure. labelled “Strobes” with a permanent type



State:

Manufacturer: _____

Model: _____

Locations to be confirmed/finalized at pre-production meeting

10.99 Light Switch Configuration(s)

- Amber strobes (rear ovals) controlled with one switch
- Mini Light Bar controlled with one switch capable of amber mode
- Traffic Advisor – separate controller

10.100 Combination Turn/Stop and Taillights

- Top Mounted - One (1) per side
- Bottom Mounted - One (1) per side
- P/N Truck-Lite 44302R with P/N 44710 mounting grommets

10.101 Back-Up Lights

- One (1) per side
- P/N Truck-Lite 44206C with P/N 44710 mounting grommets

10.102 3-Light Cluster

- Three (3)
- P/N Truck-Lite10250R with P/N 10403 mounting grommets
- Located to protect from damage

10.103	Clearance Lights	<ul style="list-style-type: none">• Grote 49333 and 49332 with mounting grommets Or <ul style="list-style-type: none">• Truck-Lite 33050R and 33050Y with 3370 mounting grommets <p><u>Note: The clearance light on the service body must remain within the boundaries of the body itself.</u></p>	_____
10.104	Harness	Truck-Lite 50 Series or equivalent harness system, properly routed, internally grounded and secured	_____
10.105	Amber Strobe Lights (Warning)	<ul style="list-style-type: none">• One (1) per side• Whelen, SWS or Grote Series lighting Class 2 or equivalent• Mounting grommets <p>State: Manufacturer: _____ Model: _____</p>	_____
10.106	License Plate Light	<ul style="list-style-type: none">• Complete with license plate bracket• P/N Truck-Lite 36140 (Light)• P/N Truck-Lite 36710 (Bracket)	_____
10.107	Rear Light Mounting Location (Rear Sill)	<ul style="list-style-type: none">• Rear-Corner Clearance Lights, qty two (2), one per side• Combination Turn/Stop and Taillights, qty two (2), one per side• Back-Up Lights, qty two (2), one per side <p>The lights shall be situated so that no debris or door opening contacts/obstructs the lights.</p> <p>Location of Lights to be confirmed at pre-production meeting</p>	_____
10.108	Rear Light Mounting Location (Top-Rear of Body)	<ul style="list-style-type: none">• Combination Turn/Stop and Taillights, qty two (2), one per side• Amber Strobe Lights, qty two (2), one per side• 3-Light Cluster, qty three (3) <p>Location of Lights to be confirmed at pre-production meeting</p>	_____
10.109	Clearance Light Mounting Locations:	<ul style="list-style-type: none">• Front – qty two (2), located one on each bottom corner of body• Sides – qty two (2) per side, located on front and rear bottom corners• Rear – qty two (2), located one on each bottom or top corner <p>Location of Lights to be confirmed at pre-production meeting</p>	_____

Welding Standards

10.110	Welds	Continuous welds	_____
10.111	Standard	CSA Standard W47.1-30, (CSA W47.1, Certification of companies for fusion welding of steel) and W59-03, (CSA W59, Welded steel construction).	_____

Where Applicable:

CSA W47.2 Fusion Welding of Aluminium Company Certification,
CSA W59.2 - 2018 – Welded Aluminium Construction

10.112	Weld Spatter	All weld spatter must be removed prior to final finish	_____
--------	--------------	--	-------

Finish

10.113	Finish/Alumimum	<ul style="list-style-type: none"> • Aluminum service body primed and painted with two (2) coats of plastic urethane paint • Color impregnated to match chassis cab color (Ford Oxford White Z1) 	_____
10.114	Alumimum Components	Unfinished Material Grade corrosion-resistant 5052-H32 marine grade alumimum	_____
10.115	Deck	Deck surface properly cleaned and coated with: <ul style="list-style-type: none"> • Rust-Oleum AS5400 Anti-Slip Floor Covering or equivalent performance product • Color Black 	_____
10.116	Preparation	All steel components unless otherwise noted in these specifications shall be sandblasted, properly cleaned, primed and finished with the Endura, DuPont or Tristar paint process in order to prevent rust formation	_____

Clearance

10.117	Clearance	Clearance between aluminium service body and the back of the truck cab shall be a minimum of 3" inches in accordance with the Cab & Chassis Incomplete Vehicle Manual.	_____
10.118	Tire Clearance	Aluminium service body shall provide for an approximate 4" inch clearance with rear springs fully loaded.	_____

Installation

10.119 Not-Permitted

- Drilling on chassis frame flanges
- Welding on the chassis frame

10.120 Holes

- When necessary and permitted in accordance with manufacturers specifications and regulations holes in the frame shall be drilled, remade and deburred to fit bolts
- Bolt holes shall not have excessive play
- Holes required to run wires through shall be drilled and deburred (not punched), grommited and sealed as required when permitted.

10.121 Isolators

- All interfaces between aluminum and steel are to be separated by an approximate 1/16" inch thick rubber or neoprene sheet.
- Shall be bolted through with non-ferrous stainless-steel bolts and non-conductive bushings.

10.122 Mounting Brackets

- Shall be bolted to the frame using Grade-8 fasteners

Grade Marking	Specification	Material	Bolt and Screw Size in.	Proof Load, psi	Tensile Strength, min psi
	SAE-Grade 8	Medium Carbon Alloy Steel, Quenched and Tempered	1/4 thru 1-1/2	120,000	150,000
	ASTM-A 354 Grade BD	Alloy Steel, Quenched and Tempered			

10.123 Bolt Requirements

- All bolts must be high tensile
- Hardened washers must be installed under both the bolt head and under the nut
- All nuts need to be high tensile and self locking (Nyloc, Conelock or other suitable self-locking variation)
- At least two bolt threads must protrude from all nuts
- Any suspension component bolts must be ISO Class10.9 or SAE Grade8
- All bolts that have been installed to replace OEM bolts must be at least an equivalent class/grade.

When mounting tow couplings (towbars, fifth wheels etc.) the bolt shank needs to protrude through the entire interface of the material. This avoids stress concentration on the threaded portion and maximises the available bolt cross-section that is subject to shearing forces.

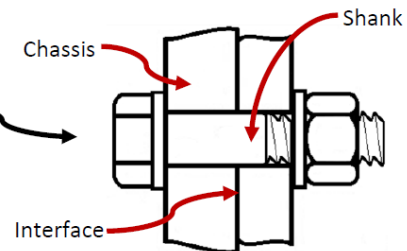
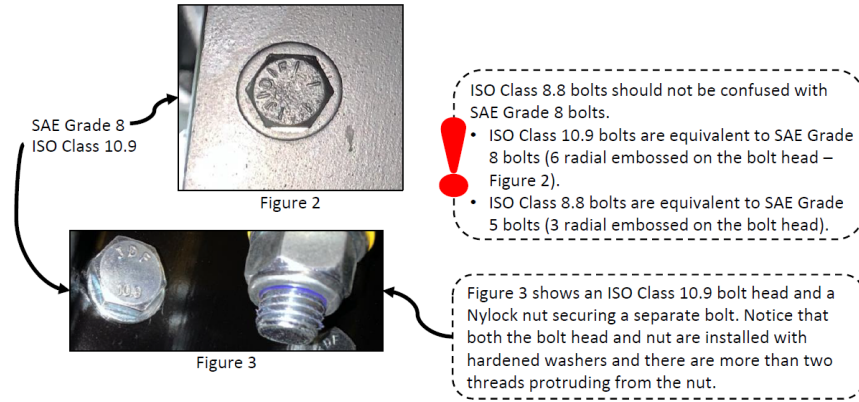

Figure 1



10.124	Mounting Standards	<ul style="list-style-type: none"> • Mounting of the body shall be in accordance with the chassis manufacture's guidelines for body mounting, including but not limited to guidelines for tire and suspension clearance and fuel filler installation. 	_____
10.125	Mountings Standards	<ul style="list-style-type: none"> • If applicable the aluminum side packs shall be mounted to the steel deck using cadmium plated carriage bolts and fender washers • Bearing plates shall be used in high stress areas. 	_____
10.126	Mounting Standards	<ul style="list-style-type: none"> • Any holes required in the frame if permitted must be drilled, reamed and deburred to fit the bolts. 	_____
10.127	Mounting Standards	<ul style="list-style-type: none"> • All non-continuous body seams (joints) shall be caulked with an automotive grade elastomeric sealant 	_____
10.128	Bolted Connections to Chassis Frame	<ul style="list-style-type: none"> • Mounting to the chassis frame is permitted however the bolt/nut assembly must have no gap or skewed connections are allowed; bolt/nut connection must be perpendicular to the clamping surface and the hole does not possess an excessive amount of play. • Not Recommended. However, if hole is to be drill to accommodate bolt/nut assembly, ensure hole is drilled far enough away from any seams, splices or overlays in the chassis frame to ensure bolted and nut/washer connection will be flat, ensure total contact with chassis frame. 	_____



The assembly of bolt and nut through the chassis frame must adhere to certain guidelines. In the event that the hole is situated on a curved surface or where a transition occurs in the frame, it is not recommended to utilize it as a mounting location.

However, if the hole location is to be utilized as a mounting location, the following protocol must be observed: A levelling washer must be employed to ensure that the bolt clamping force is fully applied and perpendicular to the frame, with no gaps permitted.

The bolt/nut assembly, located on the seam, is deemed unacceptable.

Lighting and Electrical Standards

- 10.129 Conformance:
 - LED Lighting – Class 2
 - C.M.V.S.S.
 - Manitoba Highway Traffic Act.
 - City of Winnipeg Lighting Visibility Standard

<http://winnipeg.ca/matmgt/pdfs/PublicWorksEquipLightingVisibility.pdf>

- 10.130 Visibility:
 - Taillights, back-up lights and warning lights to be fully visible when tailgate is lowered to horizontal position
 - No clearance light shall protrude beyond the service body

- 10.131 Licence plates:
 - The front license plate holder is securely installed and comes with the necessary mounting screws for the license plate.
 - The back-license plate holder is securely installed and must have an LED light to illuminate it and should be positioned on the left side at the rear of the vehicle, ensuring it is not obstructed.

- 10.132 Identification:
 - All dash mounted warning lights and switches to be identified with permanent, engraved type labels
 - Mounting of labels with 3M VHB Tape or equivalent. To ensure adhesion to interior surfaces 3M Adhesion Promoter 06396 is a convenient liquid primer for enhancing the adhesion of 3M™ Acrylic Foam Tapes in automotive applications. This adhesion promoter works with most LSE plastics used for interior and exterior automotive trim and parts
 - No labels to be located on upper surface of dash



Not Acceptable – Not Permanently Label



Picture above shows example of permanent engraved label switches.

10.133 LED Strobe Lights:

- Shall be wired “Hot” (I.e. able to be used without the key on)
- All LED strobe lights shall be wired through the ignition, wired through a single OEM dash mounted switch or on the control panel enclosure, labelled “Strobes” with a permanent type, engraved style label

10.134 Connection System:

- Weather Pack Sealed Connection System or equivalent system having same industry specifications.
- Genuine OEM connectors, terminals, and wire seals are used to guarantee quality and 100% fitment.
- (“J-Box” and shrink tube acceptable)



10.135 Grommets:

- Rubber grommets unless otherwise specified



10.136 Harnesses:

- Harness system, properly routed and secured.
- All harnesses shall be internally grounded, no exceptions
- Colour coded or numbered

10.137 Junction box:

- Complete with necessary compression fittings, required for all vehicle lighting harness connections
- Securely located – inside rear of truck frame
- Waterproof
- Readily accessible for servicing
- Protected from road spray

10.138 All Plug-In Connectors:

- All plug-in connectors shall be coated with Truck-Lite NYK Corrosion Preventive Compound prior to assembly

10.139 Compartment Lights:
• LED continuous “rope” style lighting in all service body compartments, properly secured to prevent damage _____

10.140 Wiring:
• All wiring to be colour coded, loomed and properly secured.
• Genuine OEM connectors, terminals, and wire seals are used to guarantee quality and 100% fitment for y _____
• All LED strobe lights shall be wired through the ignition, wired through a single OEM dash mounted switch or on the control panel enclosure, labelled “Strobes” with a permanent type, engraved style label

10.141 Electrical Connectors:
• All electrical connectors to be crimped, soldered and then sealed using adhesive-sealant-lined shrink tubing must be used to guarantee joint integrity, waterproofing and strain relief or rubber fittings _____



• Pictures above showing acceptable crimping and sealant using adhesive-sealant-lined shrink tubing to guarantee joint integrity and waterproofing
10.142 Joining of Wires:
• All joining of wires to be soldered and adhesive-sealant-lined shrink tubing used to guarantee joint integrity, waterproofing and strain relief _____

Note: Crimp on electrical connectors for joining wires are not acceptable

10.143 Wiring Routing:
• Any holes required to run wires through shall be drilled and deburred (not punched), grommeted and sealed _____

11.0 **WARRANTY:**

11.1 All warranty information shall be detailed and **include all exclusions.**

The Contractor shall provide all published warranty information upon delivery of the equipment. _____

Bidder shall state all warranty information.

11.2 Body **State:** _____

11.3 Crane **State:** _____

12.0 **DELIVERY:**

12.1 **Delivery Point:**

The complete unit shall be serviced, ready for operation and delivered F.O.B. with the freight prepaid, including invoice and N.V.I.S. (if applicable) to the WFMA 185 Tecumseh Street, Winnipeg MB. _____

12.2 **Delivery Time:**

Equipment shall be delivered between 8:00 am and 2:00 pm on Business Days. _____

State: earliest delivery time from date of award: _____

12.3 **Delivery Contact:**

The Contractor shall contact the Contract Administrator prior to delivery of the equipment. _____

12.4 **P.D.I.:**

A pre-delivery inspection shall be performed by the Contractor on the equipment. Proof upon inspection including completed check list _____

13.0 **MANUALS:**

13.1 **Manuals:**

The following manuals shall be supplied with the equipment when delivered: _____

Operator – Two (2) Copies

- One (1) copy shall be sent to the Equipment Operator Training Branch
- One (1) copy to be left with the equipment

Parts and Service

- One (1) complete set including preventative maintenance schedules

Note: CD or USB flash drive is preferred where available.

14.0 **PARTS/LABOUR PRICING:**

14.1 Bidder to provide City of Winnipeg Parts Discount % Pricing from retail parts pricing. **State percentage discount** _____

14.2 Bidder to provide City of Winnipeg Labor Discount % Pricing from Retail shop labor rate. **State percentage discount** _____

15.0 **FIRST SERVICE PREVENTATIVE MAINTENANCE KIT:**

15.1 If applicable, in order to assure minimum downtime of the Equipment in future service, the Contractor must provide one (1) complete replacement set of new OEM filters for each unit purchased. The set of required filters shall include (if applicable to the equipment type) air, fuel, oil, transmission, cab and hydraulic, or otherwise all known necessary common replacement filters required for the first preventative maintenance servicing and first transmission service. _____

15.2 The Contractor must provide a list of factory recommended lubricants to be used with the equipment, as well as a complete cross reference guide for all warranty approved lubricants and filters that can be used during Preventative Maintenance servicing. _____